



DEWATERING PUMPS FOR RAW WATER PUMPING



EFFICIENT STATE-OF-ART DEWATERING PUMPS

Unique user benefits

The Grundfos DW pumps form part of a complete range of wastewater and sewage handling products. Like all Grundfos products the DW pump series offer unique customer benefits, making them the natural choice for any job where raw water needs to be pumped - whether from construction sites, mining pits, excavations, or flooded basements, etc.

Grundfos offers a complete range of highly efficient dewatering pumps incorporating state-of-the-art technology. The range comprises a series of pumps from 0.7kW to 20 kW with a flow rate of 82.7 l/sec.



ADVANCED TECHNOLOGY INCORPORATED INTO AN EXCEPTIONAL RANGE OF PUMPS

The Grundfos DW range is built to last longer than conventional dewatering pumps. This is achieved through extensive use of high-grade materials such as chromium steel, nitril rubber, silicon carbide (SiC/SiC) and aluminium alloy. Various protection devices minimise potential system damage caused by overheating, whilst an integrated level switch (optional) monitors water level and automatically starts and stops the pump.

Can do more
The Grundfos DW pumps are capable of pumping water containing abrasive materials such as sand and clay particles, drill cuttings, and other potentially damaging objects that could be found on rock faces, at construction sites or in mine shafts.

The Grundfos DW pumps are suitable for all kinds of drainage and dewatering jobs:

- > Tunnels
- > Mines
- > Quarries
- > Gravel pits
- > Steel works
- > Fish ponds
- > Construction sites



Performance range

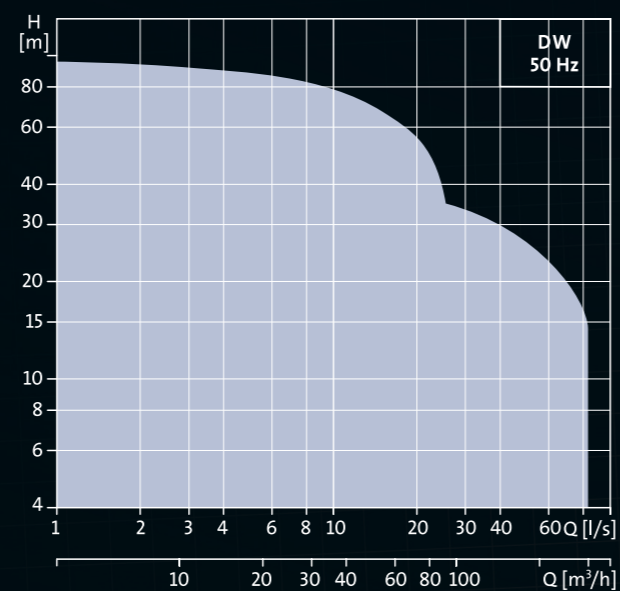

ATTENTION TO DETAIL ENABLES THE DW RANGE TO LEAD THE FIELD

The Grundfos DW range is designed with attention to every detail to ensure optimum performance and years of trouble-free operation.

Air valve for water level compartment.

Rubber covered handle

Electrical control functions are integrated into both direct-on-line and star-delta pump starting. This means that for most pump variants only one cable is required to operate the pump.

Integrated on/off switch for automatic start and stop (A), or for continuous pump operation (C).

Special low-weight, shock-resistant aluminium alloy stator housing, pump sleeve and top cover.

Electrodes for monitoring the water level in the water level compartment for automatic operation of the pump. 24V control voltage. No moving parts for start and stop signal.

Stator is insulation class F (155 C). Built-in thermal switch for protection of the motor. The motor will stop before overheating can cause any damage to the system.

Replaceable, wear-resistant nitrile rubber lining where water velocity is at its highest.

Heavy-duty, greased-for-life ball bearings. Double shaft seal system with intermediate oil chamber. SiC/SiC primary seal.

Tight-fitting, wear resistant nitrile rubber impeller back plate.

High alloyed cast iron (600 HV) semi-open impeller.

Tough, wear-resistant nitrile rubber diffuser. Easily replaceable and adjustable to ensure that optimum performance is maintained throughout the pump's life.

THE DW RANGE

The Grundfos DW pumps are portable submersible pumps with vertical discharge port. They are designed to meet the operating conditions typical of construction sites, excavations, and in the mining industry where the pumped liquid often contains sand, drill cuttings, and similar abrasive particles.

These demands are met by using only high-grade materials. All pumps are available with or without automatic level control.

(Performance overview according to ISO 9906:2012 Grade 3B).

DW.50.08.1 – single-phase
 Motor: 0.8 kW, 2800 rpm
 Max. power input: 1.3 kW
 Discharge: R 2 or 2" hose
 Weight: 13 kg (without cable)
 (With polypropylene pump sleeve)

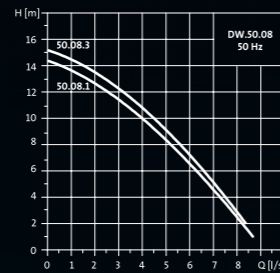

DW.50.08.3 – three-phase
 Motor: 0.8 kW, 2800 rpm
 Max. power input: 1.3 kW
 Discharge: R 2 or 2" hose
 Weight: 13 kg (without cable)
 (With polypropylene pump sleeve)

DW.50.07.1 – single-phase
 Motor: 0.7 kW, 2800 rpm
 Max. power input: 0.9 kW
 Discharge: R 2 or 2" hose
 Weight: 18 kg (without cable)

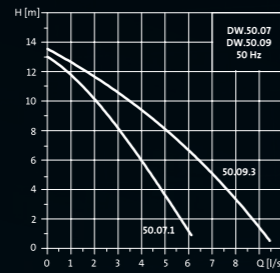

DW.50.09.3 – three-phase
 Motor: 0.9 kW, 2800 rpm
 Max. power input: 1.3 kW
 Discharge: R 2 or 2" hose
 Weight: 18 kg (without cable)

DW.65.27 – three-phase
 Motor: 2.7 kW, 2800 rpm
 Max. power input: 3.4 kW
 Discharge: R 2 1/2 or 2 1/2" hose or 3" hose connection
 Weight: 33 kg (without cable)

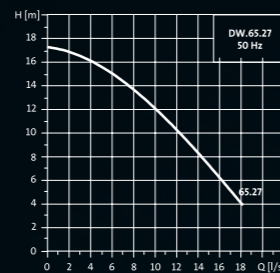

DW.65.39 – three-phase
 Motor: 3.9 kW, 2800 rpm
 Max. power input: 5.7 kW
 Discharge: R 2 1/2 or 2 1/2" hose
 Weight: 38 kg (without cable)

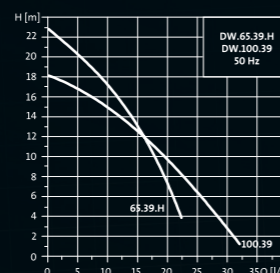

DW.100.39 – three-phase
 Motor: 3.9 kW, 2800 rpm
 Max. power input: 4.8 kW
 Discharge: R 4 or 4" hose
 Weight: 38 kg (without cable)

DW.100.66.H – three-phase
 Motor: 6.6 kW, 2800 rpm
 Max. power input: 6.5 kW
 Discharge: R 4 or 4" hose
 Weight: 51 kg (without cable)

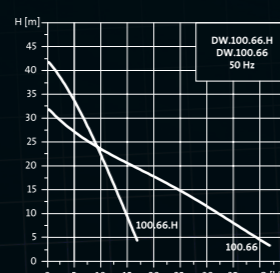

DW.100.66 – three-phase
 Motor: 6.6 kW, 2800 rpm
 Max. power input: 7.8 kW
 Discharge: R 4 or 4" hose
 Weight: 51 kg (without cable)

DW.100.110.H – three-phase
 Motor: 11 kW, 2800 rpm
 Max. power input: 12.8 kW
 Discharge: R 4 or 4" hose
 Weight: 110 kg (without cable)

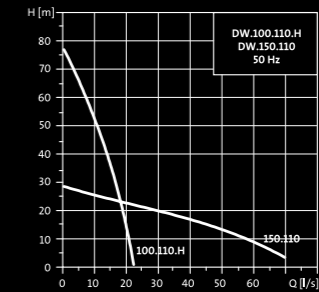

DW.150.110 – three-phase
 Motor: 11 kW, 2800 rpm
 Max. power input: 15.0 kW
 Discharge: R 6 or 6" hose
 Weight: 110 kg (without cable)

DW.100.200.H – three-phase
 Motor: 20 kW, 2800 rpm
 Max. power input: 23.0 kW
 Discharge: R 4 or 4" hose
 Weight: 148 kg (without cable)

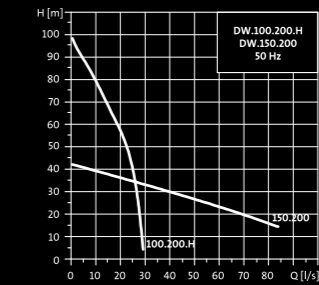

DW.150.200 – three-phase
 Motor: 20 kW, 2800 rpm
 Max. power input: 25.5 kW
 Discharge: R 6 or 6" hose
 Weight: 148 kg (without cable)

AUTOMATIC LEVEL CONTROL

The Grundfos DW pumps incorporate a highly dependable and very efficient automatic level control system, which automatically controls pump operation as the water level varies.



STAND-BY/START

The pump with automatic level control will be in a stand-by position when power is switched on and the water level is low. When the water level rises, the air will escape and the water level compartment will be filled with water.

When water comes into contact with both lower and upper electrode in the water level compartment, an electric circuit will switch on the pump.



PUMPING WATER

The water level decreases when the pump operates, but due to the water pressure inside the pump, the rubber in the air valve will expand and close the valve. This maintains a high water level in the water level compartment and the pump continues to operate.



STOP

When the outside water level is below the suction strainer, the pump will start sucking air. Air will be sucked into the water level compartment through the rubber air valve, but as long as the lower electrode is in contact with water the pump will continue to operate.

When the water level in the electrode chamber falls below the lower electrode, the electric circuit is broken and the pump stops.

TECHNICAL DATA AND DIMENSIONS

Pump type	H [mm]	D [mm]	M [mm]	S [mm]/ [inch]	Max. instalation depth [m]	Max. Q [l/sec]	Max. head [m]	P ₁ Max. [kW]	I _N [A]	$\frac{I_{start}}{I_N}$	Oil [l]	Weight [kg]
Single-phase pumps												
DW.50.07.1	395	210	212	50/2"	25	6.1	13	0.9	4	6	0.25	17
DW.50.09.A3	365	210	212	50/2"	25	6.1	13	1.0	4	6	0.25	18
Three-phase pumps												
DW.50.09.3	365	210	212	50/2"	25	9.4	13.5	1.3	2.6	6	0.25	17
DW.65.27.3	365	210	212	50/2"	25	9.4	13.5	1.3	2.6	6	0.25	18
DW.65.27.3	540	246	250	65/2½"	25	17	17.3	3.4	6.2	6	0.3	33
DW.65.27.A3	540	246	250	65/2½"	25	17	17.3	3.4	6.2	6	0.3	33
DW.65.39.3.H	605	246	275	65/2½"	25	22.2	22.8	5.7	8.6	6	0.3	38
DW.65.39.A3.H	605	246	275	65/2½"	25	22.2	22.8	5.7	8.6	6	0.3	38
DW.100.66.3.H	725	246	275	100/4"	25	16.6	42	6.6	12.5	6	0.3	51
DW.100.66.A3.H	725	246	275	100/4"	25	16.6	42	6.6	12.5	6	0.3	51
DW.100.39.3	605	246	275	100/4"	25	31.9	18.1	5.6	8.6	6	0.3	38
DW.100.39.A3	605	246	275	100/4"	25	31.9	18.1	5.6	8.6	6	0.3	38
DW.100.66.3	725	246	275	100/4"	25	41.6	32	7.8	12.5	6	0.3	51
DW.100.66.A3	725	246	275	100/4"	25	41.6	32	7.8	12.5	6	0.3	51
DW.100.110.3.H	850	360	410	100/4"	20	21.9	77	12.8	21	6	2.3	110
DW.100.110.A3.H	850	360	410	100/4"	20	21.9	77	12.8	21	6	2.3	110
DW.150.110.3	850	360	410	150/6"	20	68.9	28.5	15	23	6	2.3	110
DW.150.110.A3	850	360	410	100/4"	20	68.9	28.5	15	23	6	2.3	110
DW.100.200.3.H	1000	360	410	100/4"	20	28.6	98.2	23	40	6	2.3	148
DW.100.200.A3.H	1000	360	410	100/4"	20	28.6	98.2	23	40	6	2.3	148
DW.150.200.3	1000	360	410	150/6"	20	82.7	42.1	25.2	41	6	2.3	148
DW.150.200.A3	1000	360	410	150/6"	20	82.7	42.1	25.5	41	6	2.3	148

* With hose connection 3"

PUMPS WITH POLYPROPYLENE PUMP SLEEVE

Pump type	H [mm]	D [mm]	M [mm]	S [mm]/ [inch]	Max. instalation depth [m]	Max. Q [l/sec]	Max. head [m]	P ₁ Max. [kW]	I _N [A]	$\frac{I_{start}}{I_N}$	Oil [l]	Weight [kg]
DW.50.08.1	432	200	200	50/2"	5	8.8	14.3	1.3	6	6	x	13
DW.50.08.A1	432	200	200	50/2"	5	8.8	14.3	1.3	6	6	x	13
DW.50.08.3	432	200	200	50/2"	5	8.8	15.1	1.3	2.5	6	x	13
DW.50.08.A.3	432	200	200	50/2"	5	8.8	15.1	1.3	2.5	6	x	13

DIMENSIONAL SKETCH



TYPE KEY

Example
 DW .50.09.A3.H
 Type range _____
 Nominal diameter of discharge port _____
 Power output P2/100 (W) _____
 Operation: A = With automatic level control _____
 = For manual operation _____
 Version:
 1 = Single-phase _____
 3 = Three-phase _____
 H = High-head _____

MATERIAL SPECIFICATION

Description	Material	DIN W.-Nr.	ASTM/AISI
Stator housing	All models*: Aluminium castings. *DW.50.08 has a polypropylene pump sleeve + extruded aluminium stator housing.	3.2383	AISI A360.2
Pump sleeve		3.2383	AISI A360.2
Discharge		3.2581	AISI A413.2
Top cover		3.2581	AISI A413.2
Motor cable	20 metres, H07RN-F		
Impeller	High alloyed cast iron impeller 600HV	EN12513	
Shaft	DW.65.27 to DW.100.66: Steel shaft (1.0533) with welded stainless steel (1.4301) shaft end All other models: Stainless steel (1.4021)		
Bearings	DW.50.07 to DW.100.66: • Two single-row heavy duty prelubricated ball bearings DW.100.110 to DW.150.200 (11 and 20 kW): • Heavy-duty prelubricated ball bearings. • The lower ball bearing is a double-row ball bearing, the upper a single-row ball bearing.		
Shaft seals	DW.50.08 with polypropylene pump sleeve: • Seal bushing containing grease and a lip seal in both ends. DW.50.07 to DW.100.66 with aluminium pump sleeve: • Combination of a mechanical seal and a lip seal. • Primary seal: Mechanical seal, silicon carbide/silicon carbide. • Secondary seal: Lip seal. DW.100.110 to DW.150.200 (11 and 20 kW) • Primary seal: Silicon carbide/silicon carbide. • Secondary seal: Carbon/Ceramic.		
Bottom plate and strainer	DW.50.08: Polypropylene. All other models: Stainless steel	1.4301	AISI 304
Wear parts	Nitrile rubber		
Screws	Stainless steel	1.4301	AISI 304

PUMPED LIQUIDS

The Grundfos DW pumps are specifically designed for pumping dirty water with a high content of abrasives, such as sand, drill cuttings and similar abrasive materials.

Ph-value: 5 to 8.
 Temperature: 0 °C to +40 °C.
 Max. density: 1100 kg/m³.

MOTOR

Two-pole motors for 50 Hz with voltage tolerances of ±10%. As a protection against overload all Grundfos DW pumps have thermal overload switches in the stator windings. They break the circuit at 130 °C or 150 °C depends on the pump type.

Enclosure class: IP X8.
 Insulation class: F (155 °C).

PUMP TYPES AND PRODUCT NUMBERS

All pumps are supplied with 20 metres of cable as standard. Other lengths are available on request.

Note: Pumps without integrated motor starter for direct on-line or star-delta starting must be connected to an external control box to protect the motor against overcurrent and overload.

Pumps with aluminium sleeve

Pump type	Voltage [V]	Starting	Electrical connection				Discharge connection			Product number
			No plug	Schuko plug	Motor starter*	Prepared for external control	Hose connection	Threaded	Storz coupling half	
Single-phase pumps										
DW.50.07.1	1 x 230	DOL	x					x		96 09 02 04
DW.50.07.1	1 x 230	DOL	x					x		96 09 02 05
DW.50.07.1	1 x 230	DOL		x					x	96 09 02 38
DW.50.07.A1	3 x 230	DOL		x					x	96 09 02 39
DW.50.07.1	1 x 230	DOL		x			x			96 09 02 99
Three-phase pumps										
DW.50.09.3	3 x 400	DOL	x					x		96 09 02 06
DW.50.09.A3	3 x 400	DOL	x					x		96 09 02 07
DW.50.09.3	3 x 400	DOL			x				x	96 09 02 53
DW.50.09.A3	3 x 400	DOL			x				x	96 09 02 54
DW.50.09.3	3 x 400	DOL			x		x			96 09 03 00
DW.50.09.3	3 x 230	DOL	x				x			96 09 02 76
DW.50.09.A3	3 x 230	DOL	x				x			96 09 02 77
DW.65.27.3	3 x 400	DOL	x					x		96 09 02 08
DW.65.27.A3	3 x 400	DOL	x					x		96 09 02 09
DW.65.27.3	3 x 400	DOL			x				x	96 09 02 40
DW.65.27.A3	3 x 400	DOL			x				x	96 09 02 55
DW.65.27.3	3 x 400	DOL			x					96 09 03 01
DW.65.27.3	3 x 230	DOL	x				x			96 09 02 78
DW.65.27.A3	3 x 230	DOL	x				x			96 09 02 79
DW.65.39.3.H	3 x 400	DOL	x					x		96 09 02 10
DW.65.39.A3.H	3 x 400	DOL	x					x		96 09 02 11
DW.65.39.3.H	3 x 400	DOL			x				x	96 09 02 41
DW.65.39.A3.H	3 x 400	DOL			x				x	96 09 02 56
DW.65.39.3.H	3 x 400	DOL			x					96 09 03 02
DW.65.39.3.H	3 x 230	DOL	x				x			96 09 02 80
DW.65.39.A3.H	3 x 230	DOL	x				x			96 09 02 81
DW.100.39.3	3 x 400	DOL	x					x		96 09 02 12
DW.100.39.A3	3 x 400	DOL	x					x		96 09 02 13
DW.100.39.3	3 x 400	DOL			x				x	96 09 02 42
DW.100.39.3	3 x 400	DOL			x					96 09 02 98
DW.100.39.A3	3 x 400	DOL			x				x	96 09 02 57
DW.100.66.3	3 x 230	DOL	x				x			96 09 02 82
DW.100.66.A3	3 x 230	DOL	x				x			96 09 02 83
DW.100.66.3	3 x 400	DOL	x					x		96 09 02 14
DW.100.66.A3	3 x 400	DOL	x					x		96 09 02 15
DW.100.66.H	3 x 400	DOL	x					x		96 09 02 32
DW.100.66.3A.H	3 x 400	DOL	x					x		96 09 02 33
DW.100.66.3.H	3 x 400	DOL			x				x	96 09 02 43
DW.100.66.3	3 x 400	DOL			x				x	96 09 02 44
DW.100.66.A3	3 x 400	DOL			x				x	96 09 02 59
DW.100.66.3.H	3 x 400	DOL			x		x			96 09 03 03
DW.100.66.3	3 x 400	DOL			x		x			96 09 03 04
DW.100.66.A3.H	3 x 400	DOL			x				x	96 09 02 58

TECHNICAL DATA

Pump type	Voltage [V]	Starting	Electrical connection				Discharge connection			Product number
			No plug	Schuko plug	Motor starter*	Prepared for external control	Hose connection	Threaded	Storz coupling half	
DW.100.66.3	3 x 230	DOL	x					x		96 09 02 84
DW.100.66.A3	3 x 230	DOL	x					x		96 09 02 85
DW.100.66.3.H	3 x 230	DOL	x					x		96 09 02 86
DW.100.66.3A.H	3 x 230	DOL	x					x		96 09 02 87
DW.100.110.3.H	3 x 400	DOL	x						x	96 09 02 16
DW.100.110.A3.H	3 x 400	DOL	x						x	96 09 02 17
DW.100.110.3.H	3 x 400	Y/D	x						x	96 09 02 20
DW.100.110.A3.H	3 x 400	Y/D	x						x	96 09 02 21
DW.100.110.3.H	3 x 400	DOL			x					96 09 02 45
DW.100.110.3.H	3 x 400	Y/D	x			x				96 09 02 47
DW.100.110.A3.H	3 x 400	DOL			x					96 09 02 60
DW.100.110.3.H	3 x 400	DOL			x			x		96 09 03 05
DW.100.110.3.H	3 x 400	DOL	x			x				96 09 03 24
DW.100.200.3.H	3 x 400	DOL	x						x	96 09 02 24
DW.100.200.A3.H	3 x 400	DOL	x						x	96 09 02 25
DW.100.200.3.H	3 x 400	Y/D	x						x	96 09 02 28
DW.100.200.A3.H	3 x 400	Y/D	x						x	96 09 02 29
DW.100.200.3.H	3 x 400	DOL	x			x				96 09 02 49
DW.100.200.3.H	3 x 400	Y/D	x			x				96 09 02 51
DW.100.200.3.H	3 x 400	DOL	x							96 09 02 68
DW.100.200.3.H	3 x 400	DOL	x			x		x		96 09 03 06
DW.100.200.3.H	3 x 400	Y/D	x							96 09 02 70
DW.150.110.3	3 x 400	DOL	x						x	96 09 02 18
DW.150.110.A3	3 x 400	DOL	x						x	96 09 02 19
DW.150.110.3	3 x 400	Y/D	x						x	96 09 02 22
DW.150.110.A3	3 x 400	Y/D	x						x	96 09 02 23
DW.150.110.3	3 x 400	DOL			x					96 09 02 46
DW.150.110.3	3 x 400	Y/D	x			x				96 09 02 48
DW.150.110.A3	3 x 400	DOL			x					96 09 02 61
DW.150.110.3	3 x 400	DOL	x			x			x	96 09 02 73
DW.150.110.3	3 x 400	DOL			x			x		96 09 03 07
DW.150.200.3	3 x 400	Y/D	x						x	96 09 02 30
DW.150.200.A3	3 x 400	Y/D	x						x	96 09 02 31
DW.150.200.3	3 x 400	DOL	x				x			96 09 02 50
DW.150.200.3	3 x 400	Y/D	x				x			96 09 02 52
DW.150.200.3	3 x 400	DOL	x							96 09 02 69
DW.150.200.3	3 x 400	DOL	x				x			96 09 03 08
DW.150.200.3	3 x 400	Y/D	x							96 09 02 71
Pumps with polypropylene pump sleeve										
Single-phase pumps										
DW.50.08.1	1 x 230	DOL			x					96 09 02 00
DW.50.08.A1	1 x 230	DOL			x					96 09 02 01
DW.50.08.1	1 x 230	DOL	x						x	96 09 02 34
DW.50.08.A1	1 x 230	DOL	x						x	96 09 02 35
DW.50.08.1	1 x 230	DOL			x			x		96 09 02 96
DW.50.08.A1	1 x 230	DOL			x			x		96 09 02 97
Three-phase pumps										
DW.50.08.3	3 x 400	DOL			x					96 09 02 02
DW.50.08.A3	3 x 400	DOL			x					96 09 02 02
DW.50.08.3	3 x 400	DOL	x							96 09 02 36
DW.50.08.A3	3 x 400	DOL	x						x	96 09 02 37
DW.50.08.3	3 x 230	DOL	x					x		96 09 02 74
DW.50.08.A3	3 x 230	DOL	x					x		96 09 02 75

ACCESSORIES

Accessories			Pump type					Product number
Pos.	Description	Dimensions	DW.50.08	DW.50, 07/09	DW.65	DW.100	DW.150	
1	Chain with shackle 500kg certified - stainless steel 1.4571/A4	2 m	x	x	x	x	x	98 53 81 74
		3 m	x	x	x	x	x	98 53 81 75
		4 m	x	x	x	x	x	98 53 81 76
		6 m	x	x	x	x	x	98 53 81 77
		8 m	x	x	x	x	x	98 53 81 78
2	Coupling half, Storz coupling	Rp 2-2" hose	x	x				96 0019 82
		Rp 2½-3" hose			x			96 00 20 86
		Rp 4-4" hose				x		96 00 52 52
		Rp 6-6" hose					x	96 00 52 53
2a	Socket for hose connection	2"	x					96 00 52 18
		2"		x				96 00 60 95
		3"			x			96 00 60 96
		4"				x (DW.100.39)		96 00 60 97
		4"				x (DW.100.66)		96 00 50 49
		4"				x (DW.100.100)	x (DW.100.200)	
3	10 m flat hose, incl. Storz couplings	2"	x	x				96 00 19 87
		3"			x			96 00 52 54
		4"				x		96 00 52 55
		6"					x	96 00 52 56
4	20 m flat hose, incl. Storz couplings	2"	x	x				96 00 52 57
		3"			x			96 00 52 59
		4"				x		96 00 52 60
		6"					x	96 00 52 61
5	Bushing for pipe connection	Rp 2-2"	x	x				96 00 52 62
		Rp 2½-2"			x			96 00 52 63
		Rp 2½-3"			x			96 00 52 64
		Rp 4-4"				x		96 00 52 65
6	Union	Rp 2"	x	x				96 00 52 66
		Rp 2½"			x			96 00 52 67
		Rp 3"			x			96 00 52 68
7	Non-return valve, cast iron, ball-type valve	Rp/Rp 2"	x	x				96 00 20 02
		Rp/Rp 2½"			x			96 00 20 03
		Rp/Rp 3"			x			96 00 20 04
8	Hexagon head screw	R/R 2"	x	x				96 00 19 93
		R/R 2½"			x			96 00 19 94
		R/R 3"			x			96 00 19 95
9	Isolating valve, brass	Rp/Rp 2"	x	x				96 00 20 05
		Rp/Rp 2½"			x			96 00 20 06
		Rp/Rp 3"			x			96 00 20 07
10	Threaded flange	Rp 2½"			x			96 00 19 96
		Rp 3"			x			96 00 19 97
		Rp 4"				x		96 00 33 36
11	Gasket, bolts and nuts	4 of each M16 x 65 mm DN 80			x			96 00 19 98
		8 of each M16 x 65 mm DN 80			x			96 00 19 99
		8 of each M16 x 65 mm DN 100				x		96 00 38 23
		8 of each M20 x 75 mm DN 150					x	96 00 36 05

ACCESSORIES

Accessories			Pump type					Product number
Pos.	Description	Dimensions	DW.50.08	DW.50, 07/09	DW.65	DW.100	DW.150	
12	Non-return valve, cast iron, ball-type valve	DN 65			x			96 00 20 08
		DN 80			x			96 00 20 09
		DN 100				x		96 00 20 85
		DN 150					x	96 00 20 23
13	Isolating valve, cast iron	DN 65			x			96 00 20 10
		DN 80			x			96 00 20 11
		DN 100				x		96 00 20 12
		DN 150					x	96 00 34 27
	CE plug with phase exchanger and on/off switch	2.5-4 A	x	x				96 00 52 50
		6.3-10 A			x (DW.6.5.27)			96 00 63 12
		10-16 A			x (DW.6.5.39)	x (DW.100.39) x (DW.100.66)		96 00 52 51
		16-25A				x (DW.100.110)	x (DW.150.110)	96 00 52 36

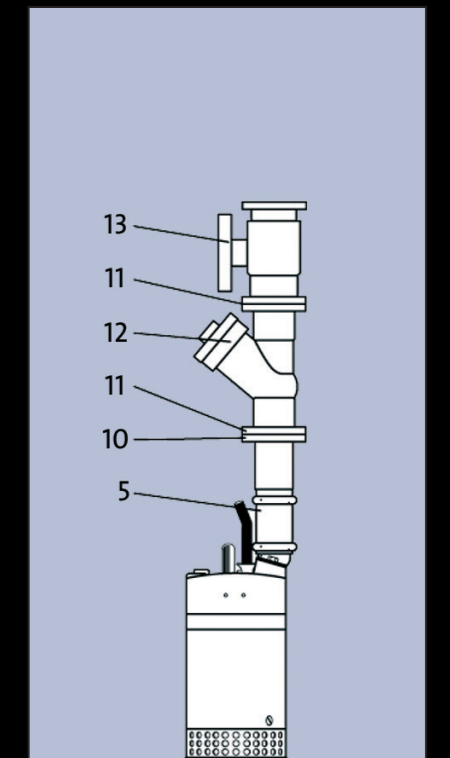
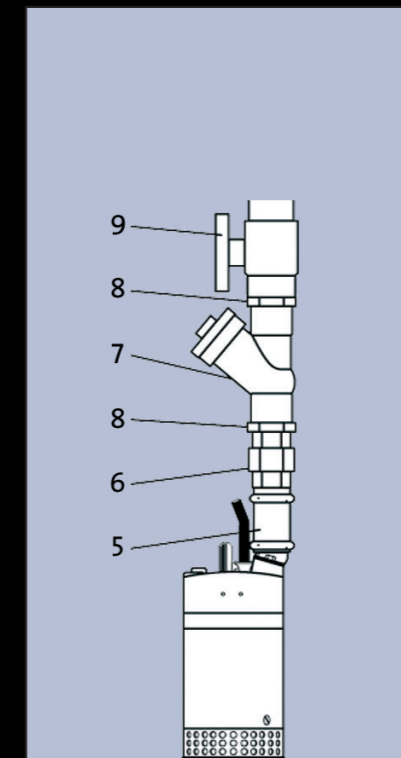
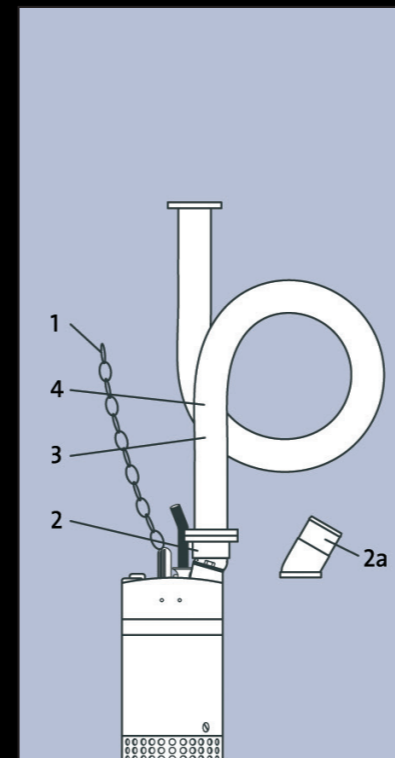



Business with an attitude

Knowledge The sharing of knowledge, experience and expertise across our global network will always lead our business forward.

Innovation Combining the best technology with fresh ways of thinking, we will continue to develop even better pumps, systems, services and standards.

Solution With a complete product range, capable of providing every conceivable water solution, we are the most complete player on the market.